

FRONT LINKAGE FRONT PTO OVERALL PROGRAM



50
YEARS OF QUALITY
1966-2016

www.hydrac.com



QUALITY MADE BY HYDRAC

MORE THAN 50 YEARS





HYDRAC is a leading company in the product ranges front-loaders, front-PTO, front-linkages and municipal equipment. With the philosophy "For every truck and tractor, for every job and for each customer the suitable equipment", HYDRAC offers a wide range of products with many different options.

Due to centuries of experience in research/development and the use of modern production methods, we were able to gain market advantage in development and technology. Our quality management system according to ISO9001 ensures best quality and performance.

Perfect service: Extensive consultation and quick customer service is at the top of HYDRAC's priorities! An additional plus: Special requests can be fulfilled in a short and easy way!

SERIES F-CS



FRONT LINKAGE SERIES F-CS (COMPACT)

Stiff construction with 3-arm positioning, fix mounted.

STANDARD EQUIPMENT

- ▶ Arms are foldable and are curved upwards to the inside (for no limitation of a front loader)
- ▶ Swing compensation
- ▶ Stopcock in supply pipe
- ▶ Top link
- ▶ Drawbar
- ▶ Double-acting lifting cylinder
- ▶ Walterscheid lower link hook cat 2.
- ▶ Painting in tractor colours

Type	F2-CS	F3-CS	F4-CS
Lifting force at 175 bars, approx.	2000 kg	3000 kg	4000 kg
Lifting height, approx.	900 mm	900 mm	950 mm
Recommended tractor power approx.	up to 85 HP	up to 140 HP	up to 200 HP

SERIES F-CSI



FRONT LINKAGE SERIES F-CSI (INTEGRATED)

Stiff construction with 3-arm positioning, fully integrated.

STANDARD EQUIPMENT

- ▶ Arms are foldable and are curved upwards to the inside (for no limitation of a front loader)
- ▶ Swing compensation
- ▶ Stopcock in supply pipe
- ▶ Top link
- ▶ Drawbar
- ▶ Double-acting lifting cylinder
- ▶ Walterscheid lower link hook 2 cat.
- ▶ Painting in tractor colours

Type	F3-CSI
Lifting force at 175 bars, approx.	3000 kg
Lifting height, approx.	900 mm
Recommended tractor rating, approx.	up to 140 HP



SERIES F-US



FRONT LINKAGE SERIES F-US (UNIVERSAL) detachable

Easy to park- and height-adjustable!
To be used on multiple tractors!

Also available as a self-adaption kit!

STANDARD EQUIPMENT

- ▶ Arms foldable
- ▶ Swing compensation
- ▶ Stopcock in supply pipe
- ▶ Single-acting lifting cylinder
- ▶ Walterscheid lower link hook 2 cat.
- ▶ Painting in tractor colours

COMFORT PACKAGE

- ▶ Top link
- ▶ Drawbar
- ▶ Double-acting lifting cylinder

Type	F2-US	F3-US
Lifting force at 175 bars, approx.	2000 kg	3000 kg
Lifting height, approx.	900 mm	900 mm
Recommended tractor rating, approx.	up to 85 HP	up to 130 HP

MOUNTING BRACKETS FOR SELF ASSEMBLING

Bolt diameter Ø 30 mm
For welding with an existing frontloader console or self-adaption.

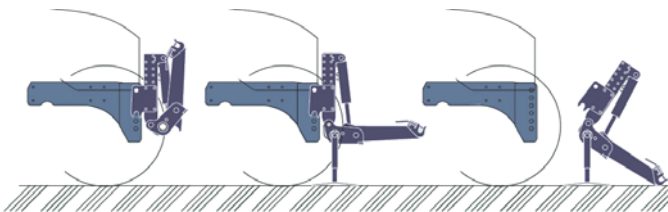

MUNICIPAL PLATE



MUNICIPAL PLATE (EURO size 3) FOR FRONT LINKAGE

- ▶ EURO attachment size 3
- ▶ Implementation instead of lower link
- ▶ Incl. top link fixture
- ▶ Suitable for front linkage by HYDRAC, original Steyr/Case, Fendt, Zuidberg, Stemplinger, Sauter;

SERIES F-USK



FRONT LINKAGE SERIES F-USK (FOR MUNICIPAL PLATE COMBI)

ONE console for mounting a front linkage and snow plough.

STANDARD EQUIPMENT

- ▶ Arms foldable
- ▶ Swing compensation
- ▶ Stopcock in supply pipe
- ▶ Top link
- ▶ Drawbar
- ▶ Double-acting lifting cylinder
- ▶ Walterscheid lower link hook 2 cat.
- ▶ Parking supports
- ▶ Painting HYDRAC black or RAL 2011

Type	F2-CS	F3-CS	F4-CS
Lifting force at 175 bars, approx.	2000 kg	3000 kg	4000 kg
Lifting height, approx.	900 mm	900 mm	950 mm
Recommended tractor power approx.	up to 88 HP	from 75 HP	from 120 HP

SERIES F-USP



FRONT LINKAGE SERIES F-USP (FOR PLATE)

For hooking onto the size 3 municipal plate or on request also for a plate size 5.

STANDARD EQUIPMENT

- ▶ Arms foldable
- ▶ Swing compensation
- ▶ Stopcock in supply pipe
- ▶ Top link
- ▶ Drawbar
- ▶ Double-acting lifting cylinder
- ▶ Walterscheid lower link hook 2 cat.
- ▶ Parking supports
- ▶ Painting HYDRAC black or RAL 2011

Type	F3-CSI
Lifting force at 175 bars, approx.	3000 kg
Lifting height, approx.	900 mm



HYDRAULIC

LOAD RELIEF UNIT HGE

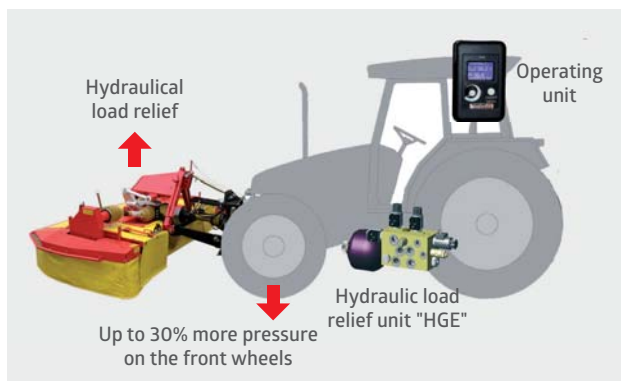

An infinitely adjustable load relief of the snow plough or mower leads to an increasing front axle load - Advantages are:

- ▶ More load on the front axle
- ▶ Increases driving safety due to better directional stability
- ▶ Up to 30% more pressure on the front wheels
- ▶ Better and perfect grass cut

Easy operation via soft keys -easily adjustable.



HGE control unit

Linkage operation, electrical:

- ▶ Infinitely adjustment of load relief at the operating unit with a potentiometer.
- ▶ Discharge possibility up to 85% of the equipment weight.
- ▶ An integrated 3D tilt sensor detects the inclination of the tractor in terrain, which is integrated in the operating unit. The relief pressure may correct automatically the pitch up or down.
- ▶ Memory for up to 6 different implements

STRONG FEATURES

FOR HYDRAC

HYDRAC front PTOs have proven themselves for years in the toughest operations. The sophisticated technology not only guarantees the best quality but also enormous operational safety. With HYDRAC you can always have a reliable partner at your side.

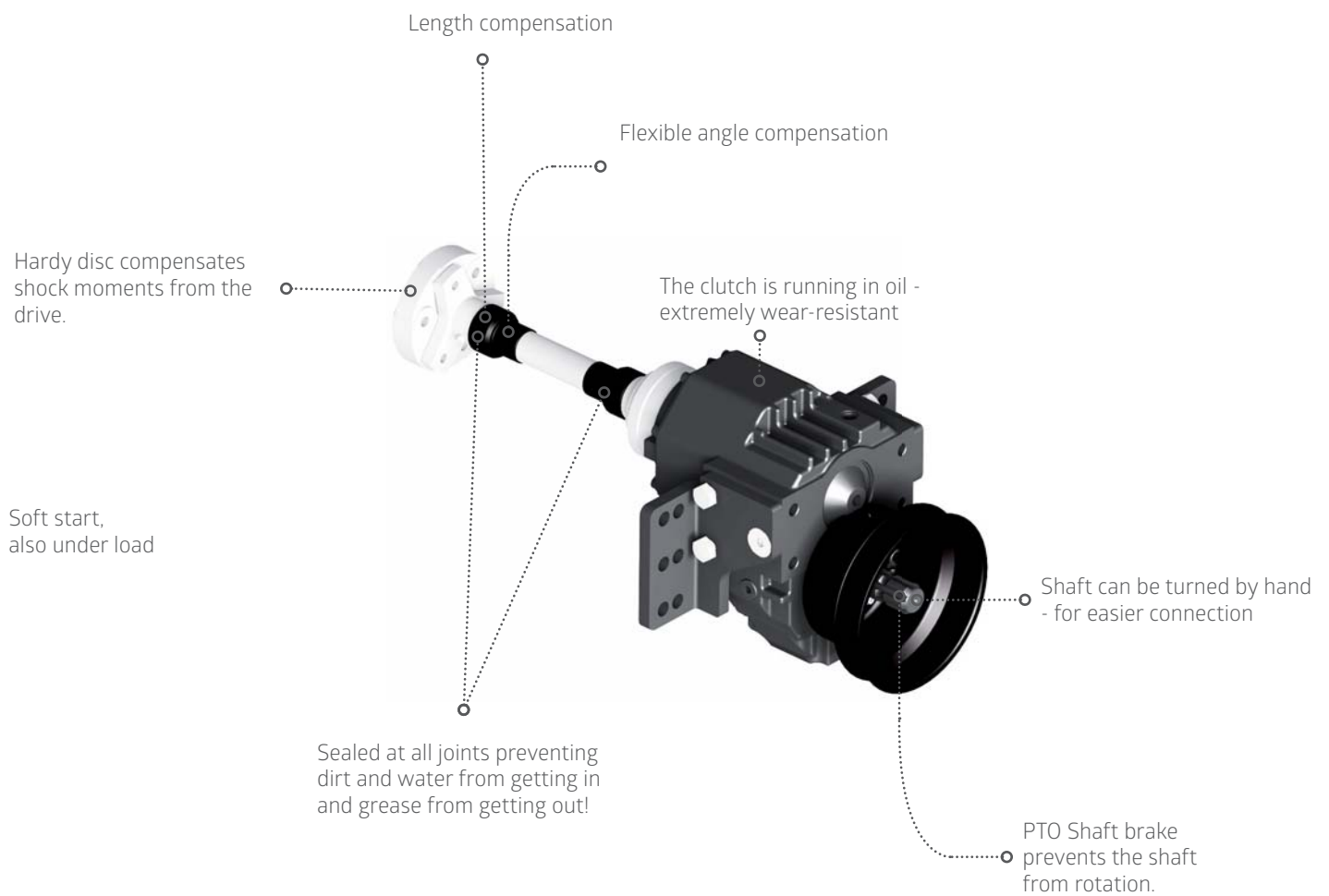

SERIES 1000

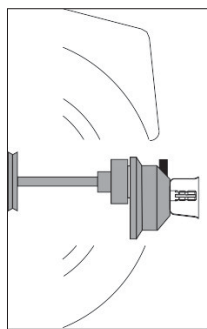

STANDARD EQUIPMENT

- ▶ 1 drive shaft: 1000 rpm right, in driving direction
- ▶ In oil running multi-plate clutch for very soft start
- ▶ Electrohydraulic start control
- ▶ No control unit from the tractor is necessary
- ▶ In oil running shaft brake

SERIES DUO

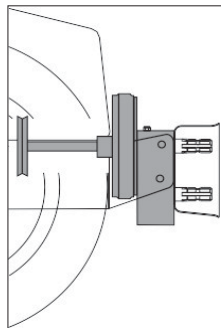

STANDARD EQUIPMENT

- ▶ 2 driveshafts: 1000 rpm right and 540 rpm on the left, in the direction of travel
- ▶ Electromagnetical single disc clutch
- ▶ Electrically start control including closing lock
- ▶ No control unit from the tractor is necessary

see type catalogue

SHIFT TRANSMISSION



For use of Unimog's implements; so that the tractors PTO remains in the same position as the unimog 1000 rpm rotation direction right side.



ADDITIONAL EQUIPMENT OF HYDRAC

HYDRAC offers a variety of options and additional equipment, which makes your machine even more universal and guarantees longer lasting.

FRONT & REAR COUNTER WEIGHTS



500 kg



800 kg

3-point attachment 2 cat.

- ▶ 500 kg
- ▶ 800 kg
- ▶ 1000 kg
- ▶ 1200 kg
- ▶ 1400 kg



1000 kg



1200 kg



1400 kg

REAR COUNTER WEIGHT



500 kg



800 kg

Tractor linkage / drawbar

- ▶ 500 kg
- ▶ 800 kg

OPTIONAL AVAILABLE



Parking supports
for easy parking



Vibration damping SDF
mechanically controllable
The vibration damper absorbs vibrations and
reduces front loader and tractor wear.



Relief spring holders
(for front mowing)



2 additional hydraulic lines with forward
plug coupling socket
(1 DW = double-acting)

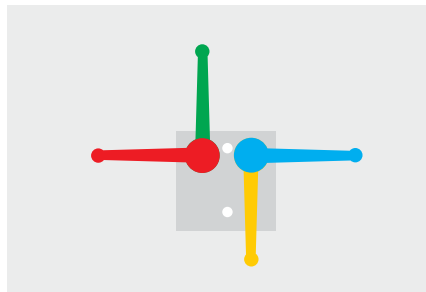

Switch valve SA/DA



Lift work operation, electrically
mounted on front linkage
(only possible when the tractor's control
device is available!)



Municipal plate



Support beam UK (up to clutch housing)
Support beam UH (up to rear axle)



Mounting brackets for self assembling



Dealer:

www.hydrac.com

HYDRAC Pühringer GmbH&CoKG
Kommunal- und Landtechnik
Primitstraße 4, AT-4523 Sierning
tel +43-7259-6000-0 · fax +43-7259-6000-40
office@hydrac.com · www.hydrac.com

Errors and modifications reserved.
Information subject to change without prior notice.
40800061 – 20200529 © HYDRAC

